

How to Adjust the Blade Diameter:

1. Turn the Set Screw with an Allen Key to obtain your desired blade diameter (D2).

NOTE: Turn counter clockwise to increase the diameter and turn clockwise to decrease the diameter.

2. Measure the blades to make sure you have the correct diameter.

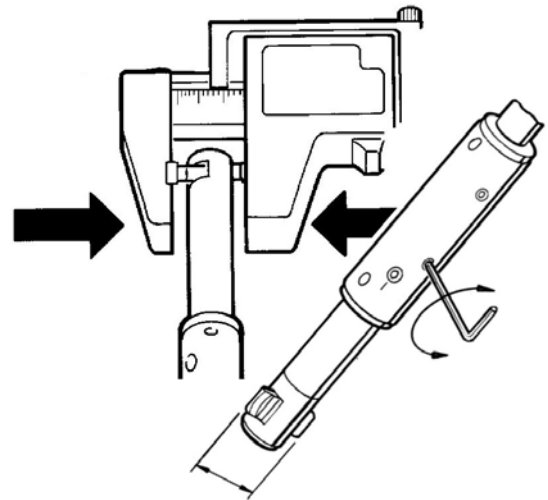

How to Adjust the Blade Force:

1. Turn the tension screw with an Allen Key to obtain the desired blade force.

NOTE: Turn counter clockwise to decrease the blade force and turn clockwise to increase the blade force.

2. Use your fingers to check the blade force, it should be tight enough that the blades pop out after being pushed in, but loose enough that they can be pushed together.

