

Replacing the Blades:

1. Unscrew the screw for each blade that attaches it to the tool body.
2. Place the new blade on the tool body and insert the screw. Repeat for each blade.

NOTE: Be sure to replace the entire set of blades and not just one single blade as they come in sets.

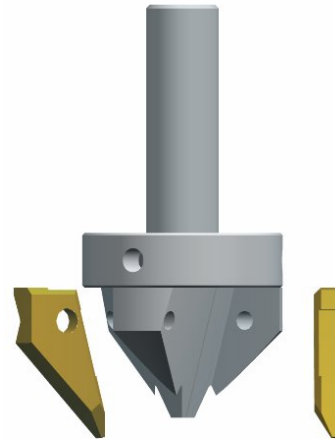

GH-K Programming				
Feed:	0.002" (0.05mm) per blade. Depending upon the material and machine rigidity, or with the use of shims, the feed rate can be increased.			
Speed:	Material	HSS-TiN	Carbide	Carbide-TiN
(SFM):	Aluminum	80-230	80-360	100-450
	Cast Iron	50-100	65-125	80-156
	Carbon Steel	33-65	50-100	82-125
	Stainless Steel	30-50	35-65	45-80
	High Temp Alloy	16-30	25-40	50-75