

## 3. Tool Maintenance

### 3.1. Changing blades

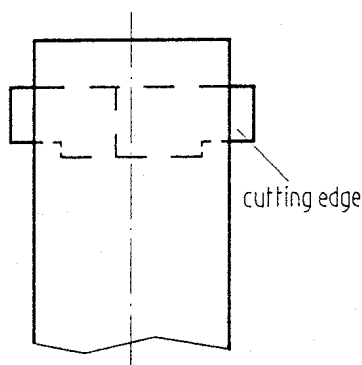
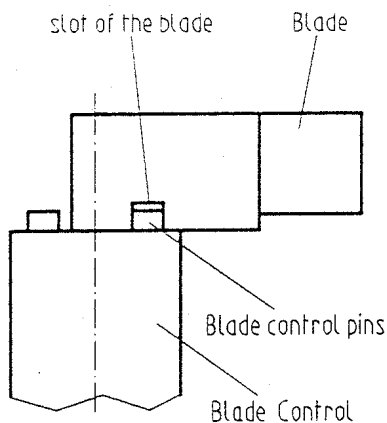
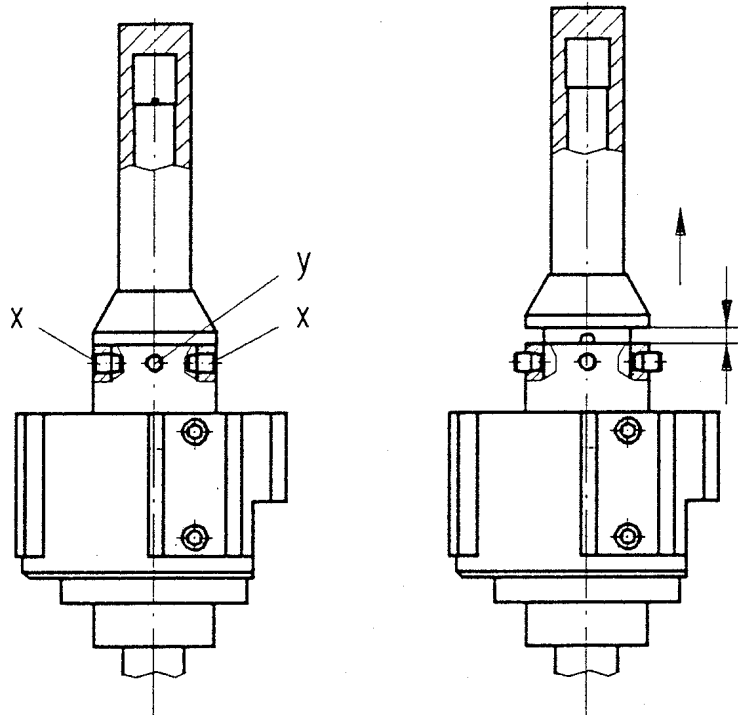

Loosen stop screw "Y" (one turn only).

Loosen clamping screws "X" until the blade housing freely slides forward.

Push the blade housing away from the tool head to the stop. The cutting blades can now easily be removed from the blade window as the pins of the blade control are no longer engaged in the blade control slot of the blades.

Insert the new set of blades into the blade window so that the cutting edges stand only 2-4mm out of the blade window.

The blades cannot be inserted the wrong way as the position of the blades is defined by a guiding chamfer on the blades.

"Press" the blade housing lightly against the tool head and at the same time slowly twist the tool shank until the pins of the blade control engage in the blade control slots of the blades and the blade housing clings again to the tool head.

Retighten the clamping screws "X" evenly and afterwards also tighten stop screw "Y".

Check whether the clamping screws "X" are securely fastened.

By twisting the tool shank (hold the tool head firmly) the blades should move in and out easily.