

VEX-S

NEW Through Hole Drilling & Chamfering System



Combination Drill and Front & Back Chamfering of Through Holes

High Performance Solid Carbide Drill combined with our patented SNAP™ Deburring System

- New VEX drill geometry for better chip control
- Quick and easy drill tip and deburr blade replacement
- No presetting between drill changes

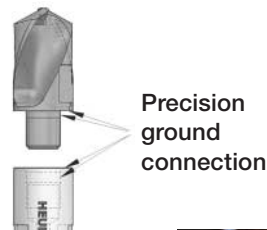

The fastest and most accurate choice for drilling and deburring through holes.



Built for high production environments

HEULE



TOOL CORPORATION

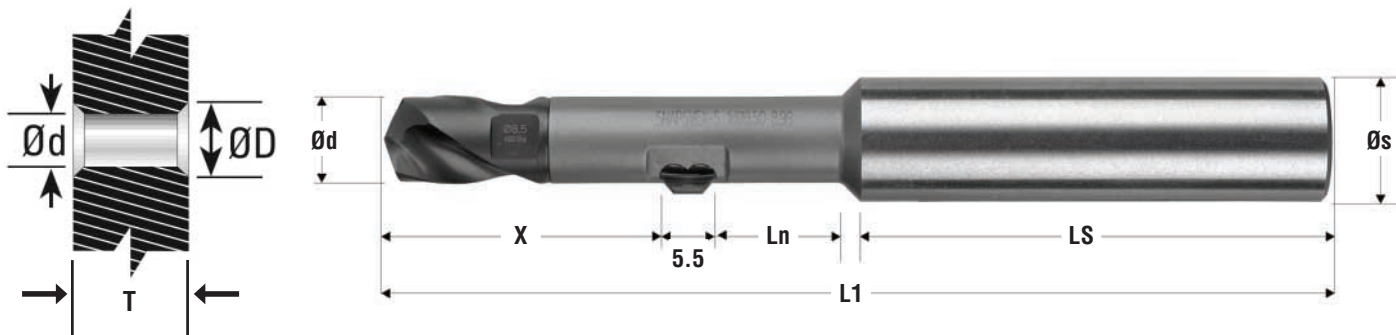

Drilling and Front and Back Chamfering

Standard 1 x dia. Length for holes 5.0-10.0mm

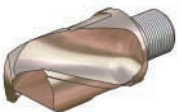
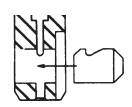

Series		Ød Drill mm (inches)	Tool Holder	T	X	L1	Ln	Ls	Øs	Chamf. Blade 	ØD	Wrench 
B	P-S-B2-0500-1H	5.0mm (.197)	VEXS-5.0-1d	5.5	18.9	70.5	7.5	36	8	GH-Q-M-30205	6.0	GH-H-S-2301
	P-S-B2-0510-1H	5.1mm (.201)	VEXS-5.0-1d							GH-Q-M-30205	6.0	
	P-S-B2-0550-1H	5.5mm (.217)	VEXS-5.5-1d	6.0	19.8	71.6	8.0			GH-Q-M-30206	6.5	
C	P-S-C2-0600-1H	6.0mm (.236)	VEXS-6.0-1d	6.5	20.6	77.7	8.5	40	10	GH-Q-M-30207	7.0	GH-H-S-2302
	P-S-C2-0635-1H	6.35mm (1/4")	VEXS-6.0-1d									
	P-S-C2-0650-1H	6.5mm (.256)	VEXS-6.5-1d	7.0	21.6	78.9	9.0			GH-Q-M-30208	7.5	
	P-S-C2-0680-1H	6.8mm (.268)	VEXS-6.5-1d							GH-Q-M-30209	8.0	
	P-S-D2-0700-1H	7.0mm (.276)	VEXS-7.0-1d	7.5	23.8	81.4	9.5			40	10	
D	P-S-D2-0714-1H	7.14mm (9/32")	VEXS-7.0-1d							GH-Q-M-30209	8.0	GH-H-S-2303
	P-S-D2-0750-1H	7.5mm (.295)	VEXS-7.5-1d	8.0	24.6	82.4	10.0			GH-Q-M-30210	8.5	
	P-S-D2-0794-1H	7.94mm (5/16")	VEXS-7.5-1d							GH-Q-M-30211	9.0	
	P-S-D2-0800-1H	8.0mm (.315)	VEXS-8.0-1d	8.5	25.4	89.5	10.5	45	12	GH-Q-M-30211	9.0	
	P-S-D2-0840-1H	8.4mm (.331)	VEXS-8.0-1d							GH-Q-M-30212	9.5	
	P-S-E2-0850-1H	8.5mm (.335)	VEXS-8.5-1d	9.0	26.6	90.9	11	45	12	GH-Q-M-30212	9.5	
E	P-S-E2-0873-1H	8.73mm (11/32")	VEXS-8.5-1d							GH-Q-M-30213	10.0	GH-H-S-2303
	P-S-E2-0900-1H	9.0mm (.354)	VEXS-9.0-1d	9.5	27.4	91.9	11.5			GH-Q-M-30213	10.0	
	P-S-E2-0935-1H	9.35mm (.368)	VEXS-9.0-1d							GH-Q-M-30213	10.0	
	P-S-E2-0950-1H	9.5mm (.374)	VEXS-9.5-1d	10.0	28.3	93.1	12			GH-Q-M-30214	10.5	
	P-S-E2-0953-1H	9.53mm (3/8")	VEXS-9.5-1d							GH-Q-M-30214	10.5	
	P-S-E2-1000-1H	10.0mm (.394)	VEXS-10.0-1d	10.5	29.5	95.1	12.5	45	14	GH-Q-M-30215	11.0	

Note: Chamfer Blades are interchangeable; maximum chamfer diameter ØD=HoleØd+2mm

Sample Order:
Ø3/8" Drill Hole

- 1pc P-S-E2-0953-1H VEX-S DRILL Ø3/8", Carb-Helica, Series E, 1:1
- 1pc VEXS-9.5-1d VEX-S Tool Holder Ø9.5 Series E, 1:1, without inserts
- 1pc GH-Q-M-30214 SNAP5 Chamfer Blade Ø10.5mm, Carb- TiAlN

Sample Order Special Drill sizes:

- Ø9.3mm Drill
- 1pc P-S-E2-0930-1H VEX-S DRILL Ø9.30mm, Carb-Helica, Series E, 1:1

- Self Centering
- Convex Cutting Edge / Concave Chip Angle
- Enlarge helix Chip Gullet for chip evacuation
- Creates very short chips / Nose Angle 140°

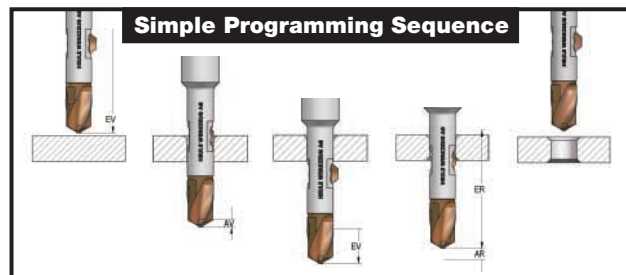

Primary usage: most steels and non-ferrous applications
Max Material Thickness 1x diameter (2xd & Specials upon request)

